

# Vertical Balers

## X-Series



### Baler X6030 LP

#### Our Machines are made safe by Design

Balers are developed and designed with the baler operator in mind.

#### Low Profile 60" Baler

The X6030 LP is low profile machine that fits under 8-foot ceiling, and still make a full 60" Mill sized bale.

#### Heavy Duty and High Pressure

With 88,000 lbs of pressure, an almost fully penetrating press plate and heavy duty frame, this machine can be used for cardboard, stretch wrap, PET, aluminum cans and others.

#### Exceed Industry Standards

Built to meet or exceed common industry safety standards. Pre-evaluated for Ontario PSR compliance.

#### Highlights

- Full 60" Mill Sized Bale
- Less than 92" installed height
- Dual-chain safety monitoring circuit
- Safe ejection of finished bale
- No risk of bale tumbling
- ANSI, UL, and CSA Compliant
- Quiet Power Unit – noise level like an office printer
- Front tie allows the baler be placed up against the wall or inside rack

#### Additional Features



BRA-IN intelligent Monitoring Systems optimizes use and Logistics



Complete installation and service available



Digital Auto-Lock prevent unauthorized access

# Product Details

## Baler X6030 LP



Whisper

30 dB



Refrigerator

50 dB

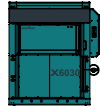

X6030 LP baler

59-60 dB



Other balers

75 dB

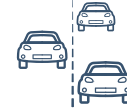

Cars on highway

100 dB



Turbojet engine

160 dB

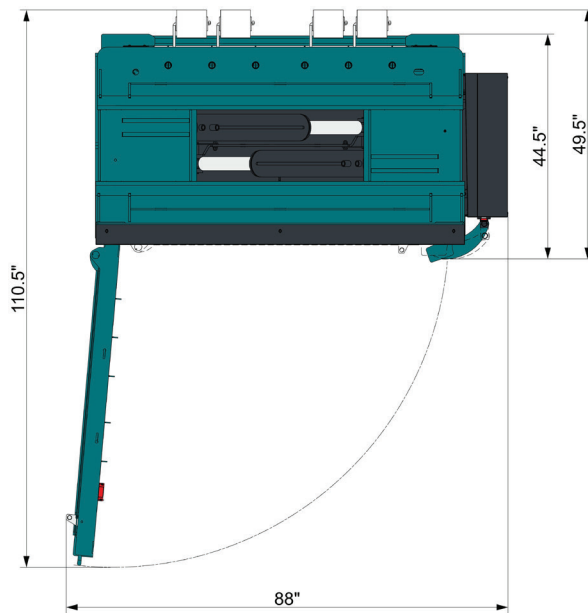
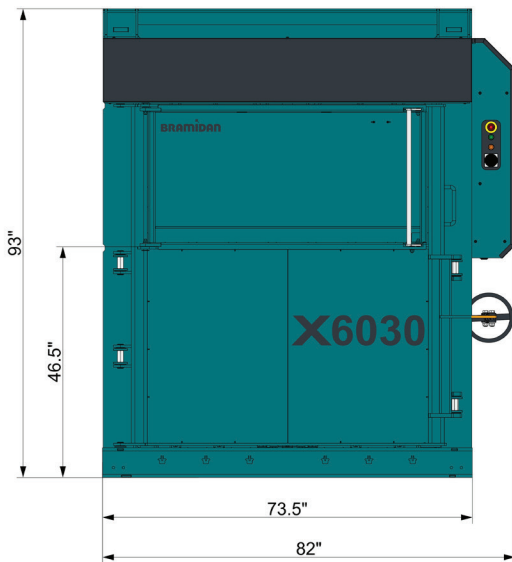

### Technical specifications

Bale size WxDxH (inch)	60 x 30 x 48
Feed opening WxH (inch)	60 x 21
Power supply	208/230/480V 3-phase
Motor (HP)	5.5
Cycle time avg. (sec)	40
Dimensions WxDxH (inch)	80 x 50 x 93
Machine weight (lbs)	4,850
Stroke (inch)	93
No. of ties	6
Type of tying	Twine / Steel wire
Full bale light	Yes
Bale eject	Automatic



### Bale weight:

Cardboard (lbs): 800-1,200  
Plastic foil (lbs): 850-1,300



### Press force:

88,200 lbs



### Noise level:

59-60 dB



### Waste types:

Cardboard, plastic foil, paper, PET bottles, aluminum and tin cans, plastic hard, textil, EPS.



sales@kernicsystems.com  
www.kernicsystems.com

### KERNIC SYSTEMS INC.

5230 South Service Rd. Unit 206  
Burlington, ON - L7L 5K2 - Canada  
Phone: 905.632.0562

### KERNIC USA, INC.

25935 Detroit Rd. #112  
Westlake, OH - 44145 - USA  
Phone: 440.250.8560